



### Attention

The Model 5000 design has changed as of August 1st, 2018. Please read the instructions to ensure it is installed correctly.



### Overview

- The Model 5000 provides 3 additional control wires and a common connection 'C' between a thermostat and indoor unit.
- The Model 5000 can not be used to extend the wiring between an indoor and outdoor unit.
- The Model 5000 is compatible with most 24V AC heating and cooling systems.

### Electrical Safety

- This product is designed for use with a Class 2 transformer providing 23 to 28 volts.
- The total connected load must not exceed 2 amps.
- The connected load cannot operate at more than 30 volts (not designed for direct connection to 120 volt equipment).
- To avoid risk of electrical shock or equipment damage, disconnect power before beginning installation.

### Sender Installation

The Sender is the smaller component and is installed inside the wall behind the thermostat.

- Remove the thermostat from the wall.
- If the hole where the thermostat cable wires come through is not big enough to fit the Sender, enlarge it.
- Place the Sender in the wall and connect the wires to the sub-base according to the wiring diagram (pages 3-4). The Sender will hang by its wires and does not require any mounting.
- Install the thermostat on the wall.

**Note:** The Sender will produce a small amount of heat while operating. Keep the Sender wires as long as possible to maximize the distance between the Sender and thermostat. Do not install the Sender in insulated walls.

### Receiver Installation

The Receiver is the larger component and is installed inside the cabinet of the indoor unit. If there is no space inside the cabinet, the Receiver may be placed in any location without exposure to high temperatures or water.

Connect the Receiver according to the wiring diagram for the system (pages 3-4).

If the installation only has single stage heat, both the white and blue wires can be connected to thermostat 'W' at the Sender and equipment 'W' at the Receiver.

Some installations may require the Receiver voltage to be adjusted. See 'Setting the Receiver Voltage' for more information.

### Setting the Receiver Voltage

The Model 5000 is factory set to be compatible with most thermostats.

Differences in transformer voltage and thermostat power consumption may require the Receiver to be adjusted. The adjustable resistor located on the side of the case can be turned to increase or decrease the Receiver voltage.

The voltage (DC) of the Receiver is measured between the Receiver's orange wire and transformer Common. It is factory set for 0.30V (with a 24.0V transformer) while disconnected from the thermostat.

Check each function on the thermostat (G, Y, W1, W2) to see if the connected equipment turns on and off correctly.

If the equipment does not turn on when called, the Receiver voltage may be too low. With the thermostat calling for any function, increase the Receiver voltage until the equipment activates. Set the voltage to 0.05V over the minimum voltage the equipment activates at.

If the equipment does not turn off when the thermostat stops calling, the Receiver voltage is too high. With the thermostat not calling for any function, decrease the Receiver voltage until the equipment turns off.

After the Receiver voltage has been set, check that all equipment turns on and off correctly. The orange wire should be taped back as it is no longer needed.

### Operation

The Model 5000 has two channels, green and yellow, and white and blue.

Applying 24V to the Sender's green wire will output 24V on the Receiver's green wire.

Applying 24V to the Sender's green and yellow wires will output 24V on the Receiver's green and yellow wires.

Applying 24V to the Sender's white wire will output 24V on the Receiver's white wire.

Applying 24V to the Sender's white and blue wires will output 24V on the Receiver's white and blue wires.

When 24V is applied to the Sender's white or blue wires, the yellow and green wires at the Receiver will not output 24V regardless of whether or not they are being called.

### Contact Us

For installation assistance, our technical support line can be reached at 1-800-775-4750, 9am-5pm PST, or emailed at [info@nordictech.ca](mailto:info@nordictech.ca)

## Troubleshooting

1. Measure the transformer voltage to check if it drops below 23V while in use. The Model 5000 may not function properly outside of the 23-28 volt range and the transformer may need to be replaced.
2. If applying 24V to 'G' on the Sender activates 'W1' on the Receiver, or vice versa, then the two wires that connect the Sender and Receiver are crossed. Disconnect the thermostat cable and swap the connections.
3. At the thermostat, jumper 'R' to 'G' to activate the fan. Jumper 'R', 'G', and 'Y' to activate the fan and condenser. Jumper 'R' to 'W1' to activate first stage heat. Jumper 'R', 'W1', and 'W2' to activate second stage heat. If all functions work correctly when jumpered, then the thermostat may not be configured properly. If no functions operate there may be a break in the thermostat cable.
4. If the Receiver is set to the highest voltage possible and still does not activate the equipment when called, then the power consumption of the thermostat is too low. This can be fixed by adding a resistor in parallel to the thermostat. See 'Low Power Thermostats' for more information.

## Low Power Thermostats

Some thermostats may not use enough power for the Model 5000 to operate as intended. A resistor can be added into the circuit to increase the amount of power sent to the Receiver, as shown in the diagram below.

A 1000  $\Omega$ , 1W resistor is recommended, however similar resistance values (750-1500  $\Omega$ ) can be used. Ensure the wattage of the resistor is 1W or more.

### Low Power Thermostats: Adding a Resistor

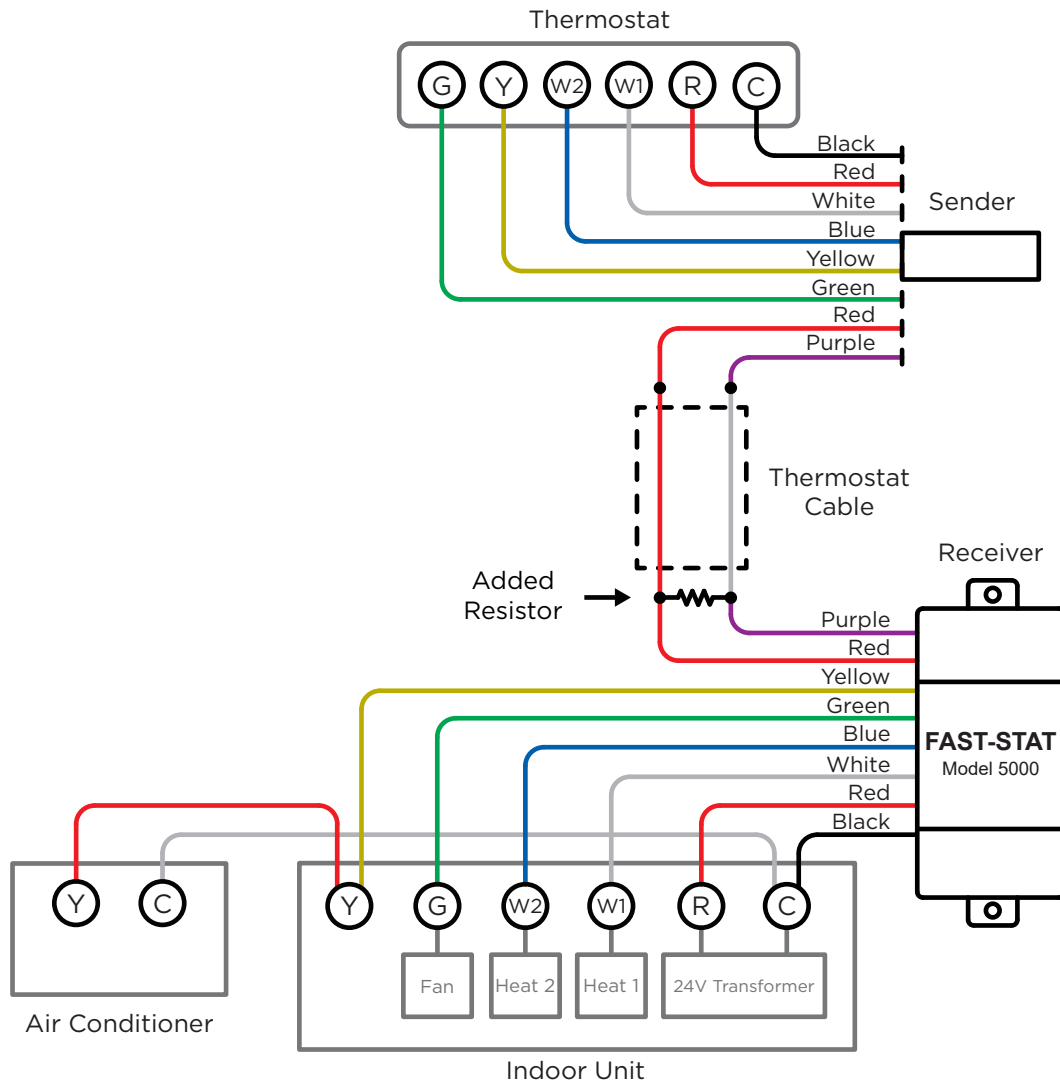

# A Thermostat Cable with Two Wires

Before

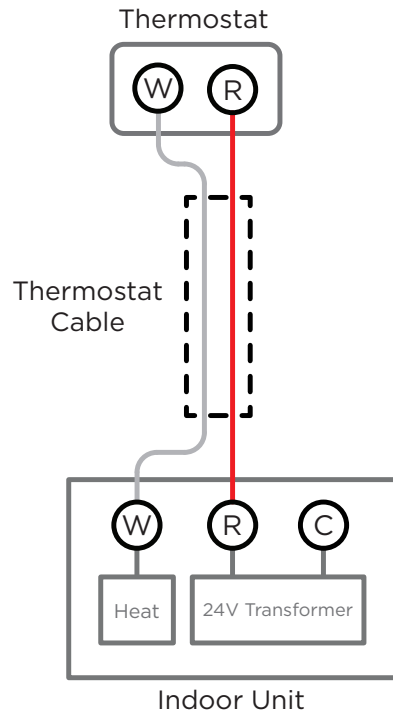

After

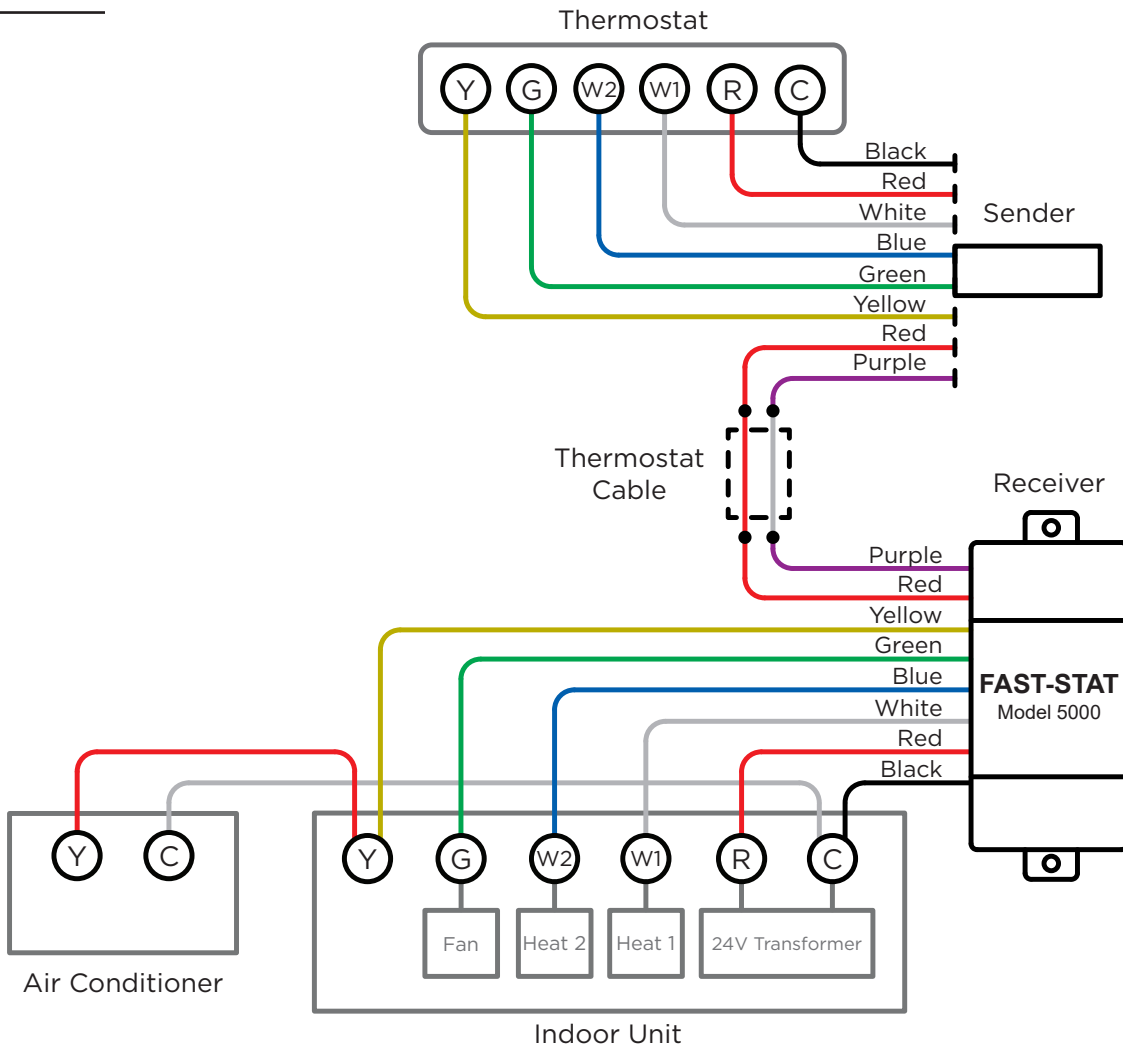

## B Thermostat Cable with Three or More Wires

Before

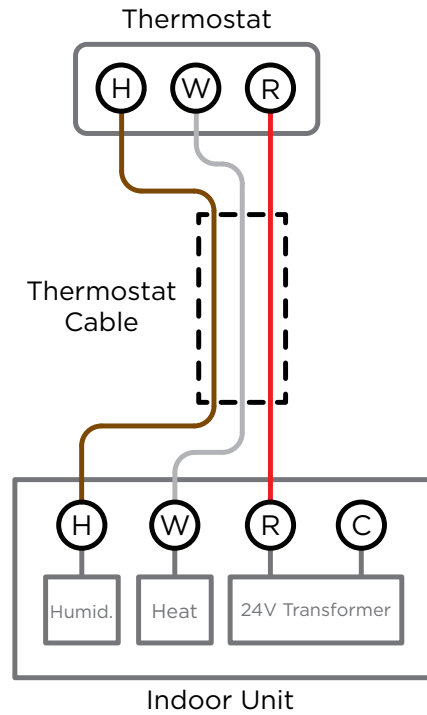

After

**Note:** Any additional wires in the thermostat cable can be connected as normal. They do not interfere with the Model 5000.

